

BAUFIX 100
UNDERFLOOR SUMP

- Use in groundwater areas possible
- Floor drain
- Includes complete internal pipework
- Level-compensating frame
- Odour-tight cover
- Seal collar for attaching to the customer's thin-bed waterproofing system
- Guide rail system for U3KS, U5KS, U6K ES/DS



DESCRIPTION

Without a great deal of construction work, underfloor sump Baufix 100 can be used to remove effluent from laundries, storage or cellar areas below the backpressure level. The use as a collecting tank for faeces is not permitted. Without formwork, the pressure-resistant plastic container is placed into the concrete bed and forms a collecting tank for underfloor pipework. The installation in areas subject to the groundwater flooding is permitted only along with additional measures (water-tight concrete shell) as the connection between PE and concrete does not withstand pressing water.

The pump to be placed can be selected according to the amount of wastewater. The dirty water to be transported and the pumping power required have to be taken into consideration in particular. In case of slightly dirty water (grain size max. 10 mm), pumps U3KS, U5KS as well as U6K ES+DS can be used. If the admixtures are larger or the volume of wastewater is bigger, the use of a pump of the US series is recommendable. Pumps US 73+103 Ex are used in hazardous areas. For the disposal of condensate from condensing boilers, the special variant U3KS spezial has to be used.

The swing type-check valve fitted in the works of the manufacturer prevents the reflux of the wastewater from the pressure pipe into the sump. The standard odour trap stops annoyance caused by offensive odour.

By subsequently adjusting the plastic cover frame, the sump cover can be adapted easily and variably to the floor and tile conditions.

The unit is in conformity with the specification of German / European standard EN 12050.

Specifications can be changed without notice. Performance subject to ISO 9906 tolerances.

PERFORMANCE

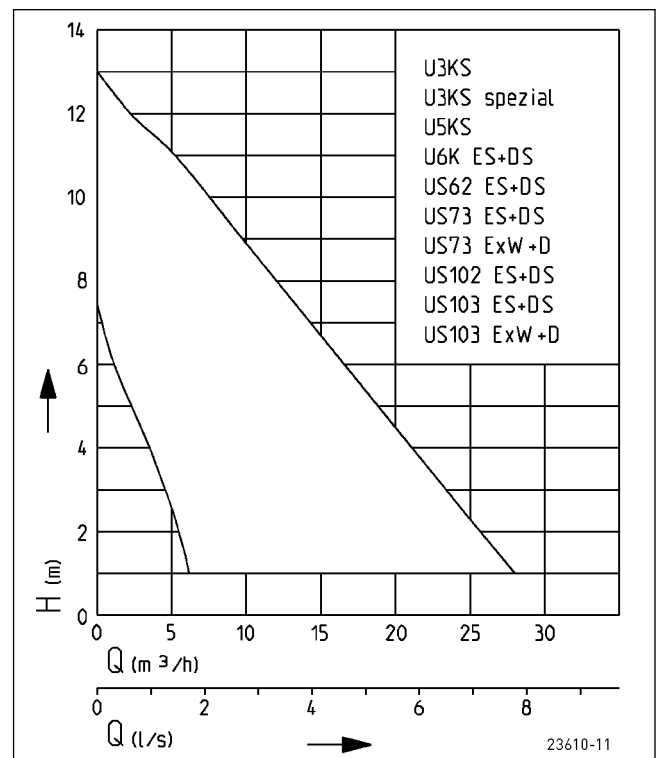

BAUFIX 100

UNDERFLOOR SUMP

SCOPE OF SUPPLY

Plastic tank to house a pump tested in keeping with German / European standard EN 12050 with shaped connecting piece and level-compensating plastic cover frame with cover plate, odour

trap for floor drain, hose connection, premounted discharge branch with swing-type check valve, parts required for pump installation, plug for cable conduit, without pump.

MECHANICAL DATA

Tank capacity	70 l	Weight	14 kg
---------------	------	--------	-------

BAUFIX 100

Type	Code No.
Baufix 100-tank	JP47214

POSSIBLE PUMPS

Baufix 100	US 62 ES/DS	US 73 E/D Ex
U3KS/U3KS spezial	US 73 ES/DS	US 103 E/D Ex
U5KS	US 102 ES/DS	
U6K ES/DS	US 103 ES/DS	

Dimensions Baufix 100 (mm)

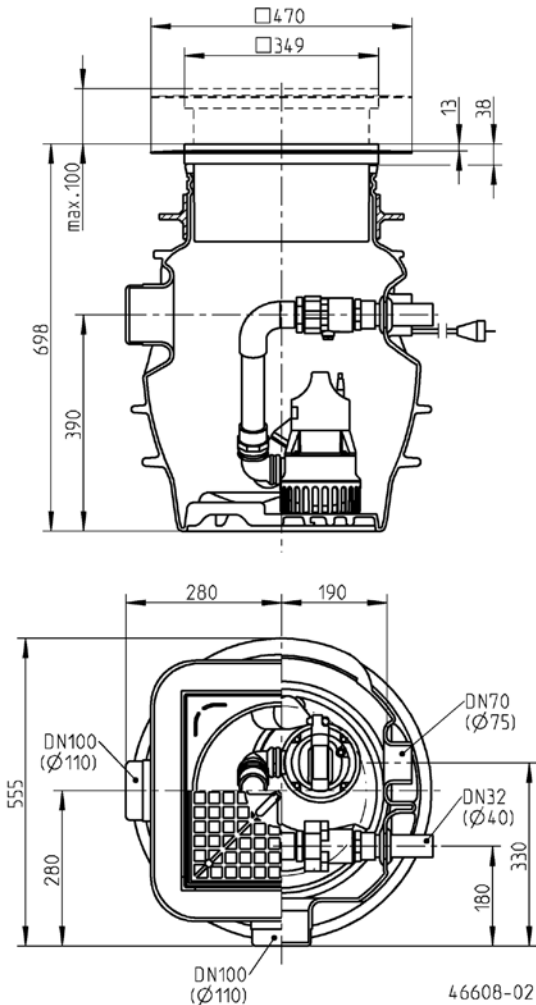





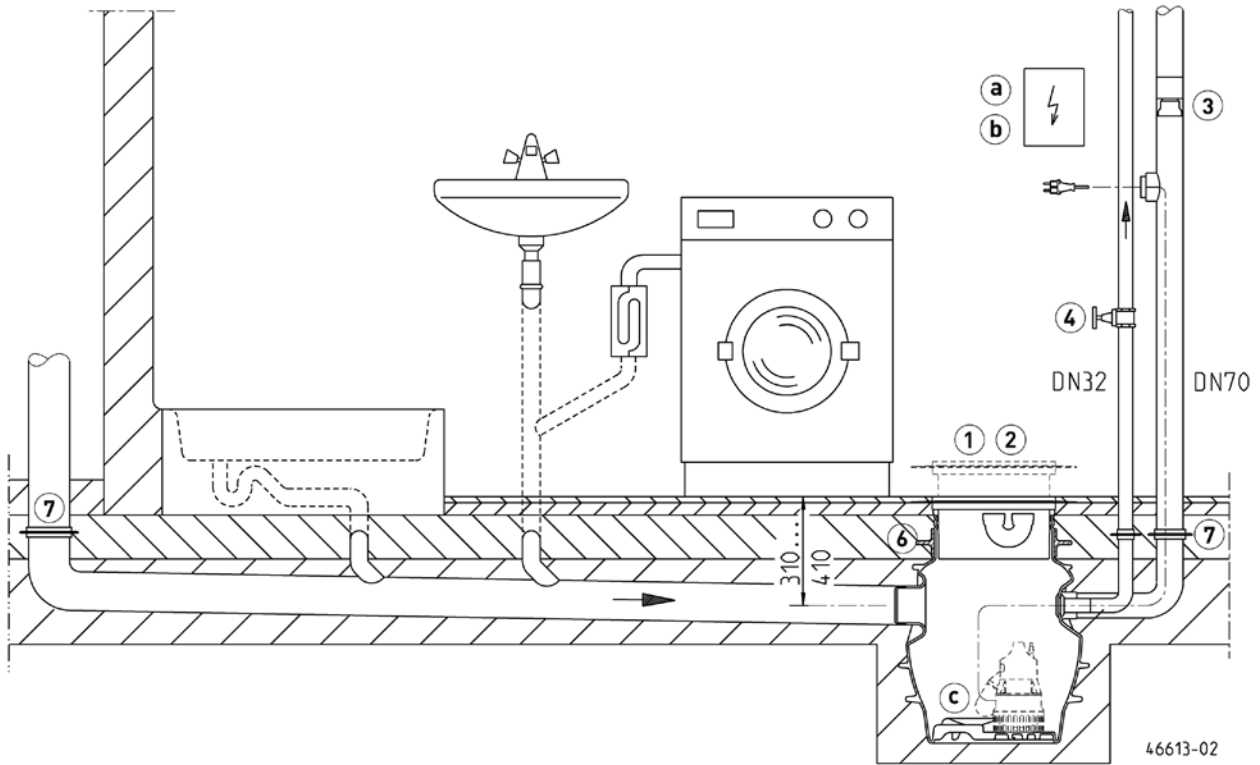

BAUFIX 100

UNDERFLOOR SUMP

Example of installation Baufix 100

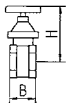



MECHANICAL ACCESSORY

				Code No.
	① Cover plate	stainless steel, to be tiled, for Baufix 50, Baufix 100, Baufix 200-32		JP24024
	② Cover frame	stainless steel, for Baufix 50, Baufix 100, Baufix 200-32		JP28118
	③ Special ventilation	special filter with housing, not for hot water		JP27484
	④ Stop valve	1/4" (DN 32), PN 16	110x60 (HxB)	JP44785
		brass, 1/2" (DN 40), PN 16	125x60 (HxB)	JP44786
	Ball valve	1/4", PVC, for aggressive media	105x155 (HxB)	JP46111
	⑤ Guide rail system	GR 32 for Baufix 100		JP46706
	⑥ Ground water seal sump	Ø315 for Baufix 100/Baufix 200-32		JP47216
	⑦ Ground water seal set	for Baufix 100/Baufix 200-32 with inlet DN 100		JP50206

BAUFIX 100

UNDERFLOOR SUMP

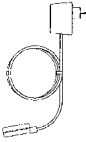
ELECTRICAL ACCESSORY

			Code No.	
	a	Control for single units		
		Control unit AD 4 XE	for US 73E EX	JP25901
		Control unit AD 8 XE	for US 103E E	JP25902
		Control unit AD 23 X	for US 73D EX	JP09754
		Control unit AD 25 X	for US 103D EX	JP09683
		Level control	LM-circuit (for explosion-proof pumps only)	JP01080
			Assembly set for LM circuit	JP22410
		Dry run protection		JP44603
		Alarm unit		
		AG3	subm. ball contact switch, mains dependent, potential-free contact, 3 m cable	JP44891
		AG10	subm. ball contact switch, mains dependent, potential-free contact, 9.5 m cable	JP44892
		Washing machine stop		
	AW3	subm. ball contact switch, mains dependent, 3 m cable	JP44895	
	AW0	for alarm forwarding in case of several washing machines	JP44899	
	b	Rechargeable battery	9 V, for mains independent alarm	JP44850
		c	Seal leak detector	DKG
			DKG Ex for explosion-proof pumps	JP00249