

**BAUFIX 50**  
UNDERFLOOR SUMP



- Odour-tight cover valve
- Floor drain
- Seal collar for attaching to the customer's thin-bed waterproofing system
- Integrated sump ventilation
- Mounted swing-type check valve
- Complete pressure pipe in the sump
- Level-compensating frame
- Quick-lock of the pump
- Two combination inlets DN 50/100

**DESCRIPTION**

Baufix 50 is a compact sump designed for the installation in foundation rafts or cellar floors. Together with the submersible motorised pump U3KS, it is suitable for the drainage of domestic wastewater from washbasins, sinks, showers and washing machines in cellars or lavatories. The floor drain in the cover of the sump protects the location against bigger floods. The introduction of wastewater from toilets and urinals is not permitted.

The pressure-resistant sump is placed into the pit without formwork; the pipes are connected and the sump embedded flush in concrete. The installation in areas subject to the groundwater flooding is permitted only along with additional measures (water-tight concrete shell) as the connection between PE and concrete does not withstand pressing water.

In combination with the height-adjustable and rotatable cover made of plastic, the shaped sump neck permits a perfect level compensation at the installation site. Thus, the installation depth of the sump may vary between 45 and 71 cm. The arrangement of the combined inlets in the lower part of the sump permits installation in flat pits as well.

The swing-type check valve fitted in the works of the manufacturer prevents the reflux of the waste-water from the pressure pipe into the sump. The standard odour trap stops annoyance caused by offensive odour. The screw clamp with wing bolt in the container ensures ease of installation and maintenance of the pump.

For deeper installation depths or more powerful pumps, we recommend the use of Baufix 100 and Baufix 200.

The unit is in conformity with the specification of German / European standard EN 12050.

Specifications can be changed without notice. Performance subject to ISO 9906 tolerances. The minimum flow velocity in the pressure piping must be 0.7 m/s according to EN 12056. This data is represented in the performance curve as a limit of application.

**PERFORMANCE**

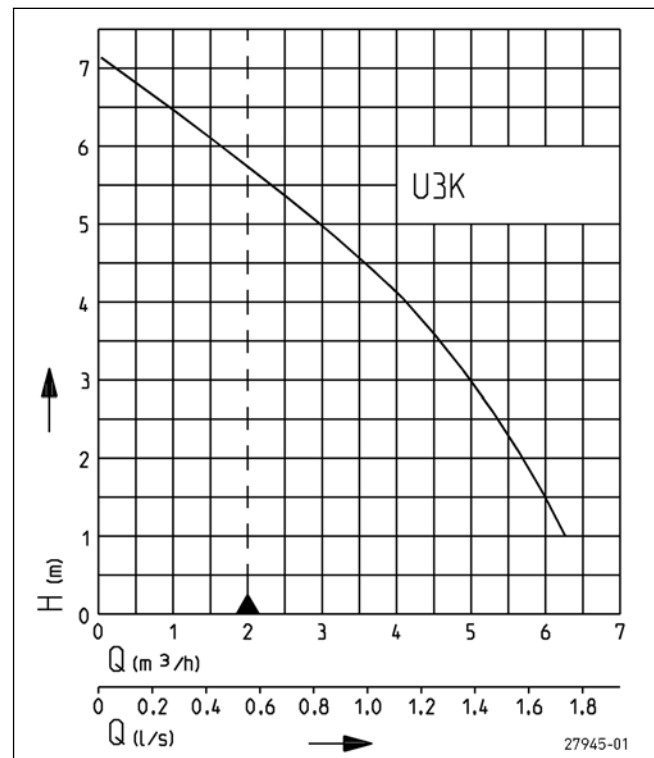

# BAUFIX 50

## UNDERFLOOR SUMP

### SCOPE OF SUPPLY

Plastic sump to house a pump tested in keeping with German/ European standard EN 12050 with shaped connecting piece, shaped sump extension, level-compensating plastic cover frame with cover plate, odour trap for the floor drain, discharge branch

with swing type-check valve and pressure pipe premounted in the tank, special float for lower switching heights, plug-in seal DN 50, closing plug for cable conduit, without pump.

### MECHANICAL DATA

Tank capacity	40-55 l	Weight	8 kg
---------------	---------	--------	------

### BAUFIX 50

Type	Code No.
Baufix 50-sump	JP09335

### POSSIBLE PUMPS

Baufix 50
U3KS/U3KS Spezial

### Dimensions Baufix 50 (mm)

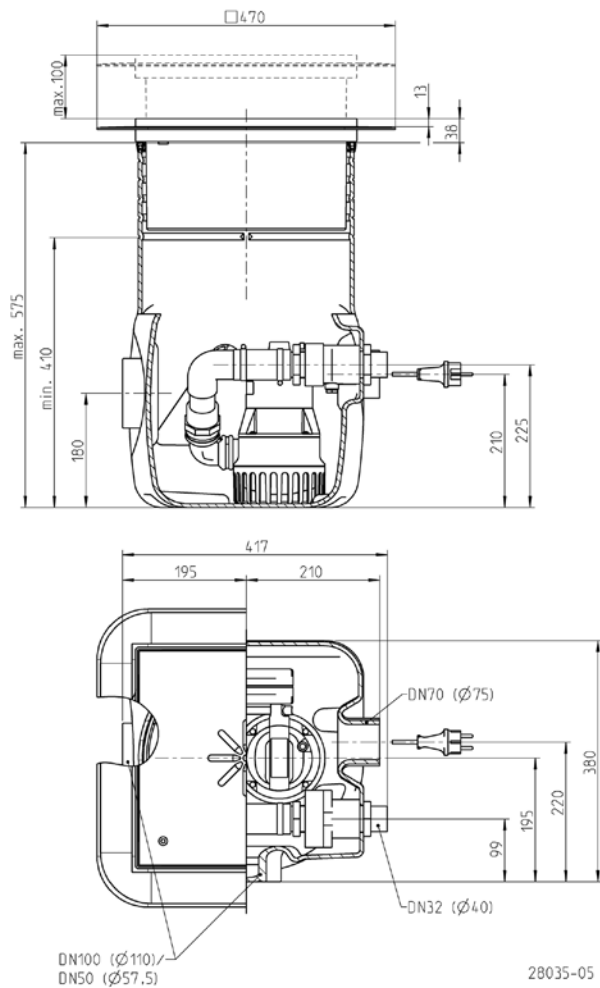



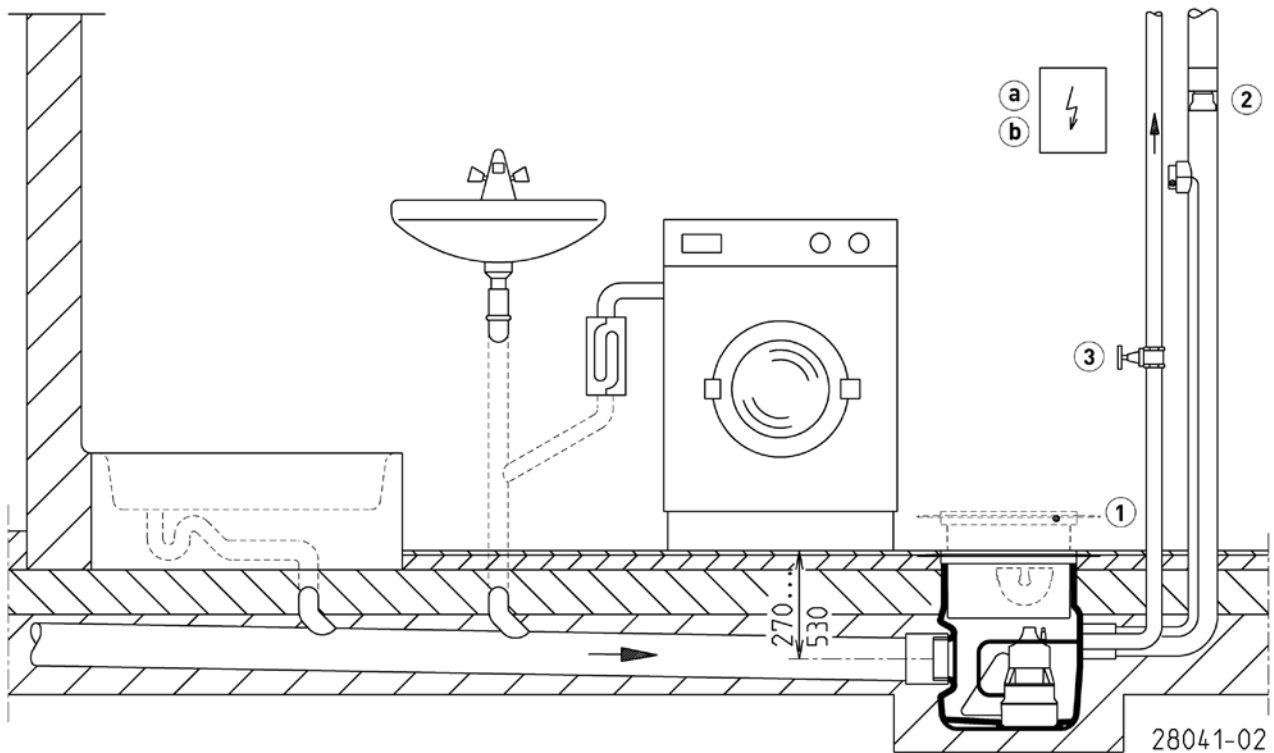

# BAUFIX 50

## UNDERFLOOR SUMP

### Example of installation Baufix 50



### MECHANICAL ACCESSORY

			Code No.
	<b>① Cover plate</b>	stainless steel, to be tiled, for Baufix 50, Baufix 100, Baufix 200-32	<b>JP24024</b>
	<b>② Special ventilation</b>	special filter with housing, not for hot water	<b>JP27484</b>
	<b>③ Stop valve</b>	1/4" (DN 32), PN 16	<b>JP44785</b>
	Ball valve	1/4", PVC, for aggressive media	<b>JP46111</b>

# BAUFIX 50

## UNDERFLOOR SUMP

### ELECTRICAL ACCESSORY

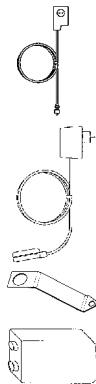
			Code No.
	<b>a Alarm unit</b>		
	AGR	reed switch, mains dependent, potential-free contact, 4 m cable	<b>JP44893</b>
	<b>Washing machine stop</b>		
	AWR	reed switch, mains dependent, 3 m cable	<b>JP44897</b>
	AW0	for alarm forwarding in case of several washing machines	<b>JP44899</b>
	<b>Fastener for alarm switch</b>	(only U3KS, U5KS and U6KS with special float switch)	<b>JP28191</b>
	<b>b Rechargeable battery</b>	9 V, for mains independent alarm	<b>JP44850</b>