

## DPC

CLEAN WATER DRENA-LINE

- Compact dimensions
- Continuous operation
- Integrated float switch
- Manual-automatic switch
- Low level pumping
- Moisture sealed cable inlet



### DESCRIPTION

The submersible pumps of the DPC series for clear water are designed for domestic use such as the drainage of infiltrated water, the collection of water from wells, basins or tanks. Check valve and hose connector adaptable for hoses of 3/4 or  $\varnothing$  25-32, included in supply.

Minimum drying level 3 mm.

### APPLICATIONS

- Drainage of infiltrated water, lifting of rainwater from grille or well
- Emptying of rooms, tanks and wells

### PERFORMANCE

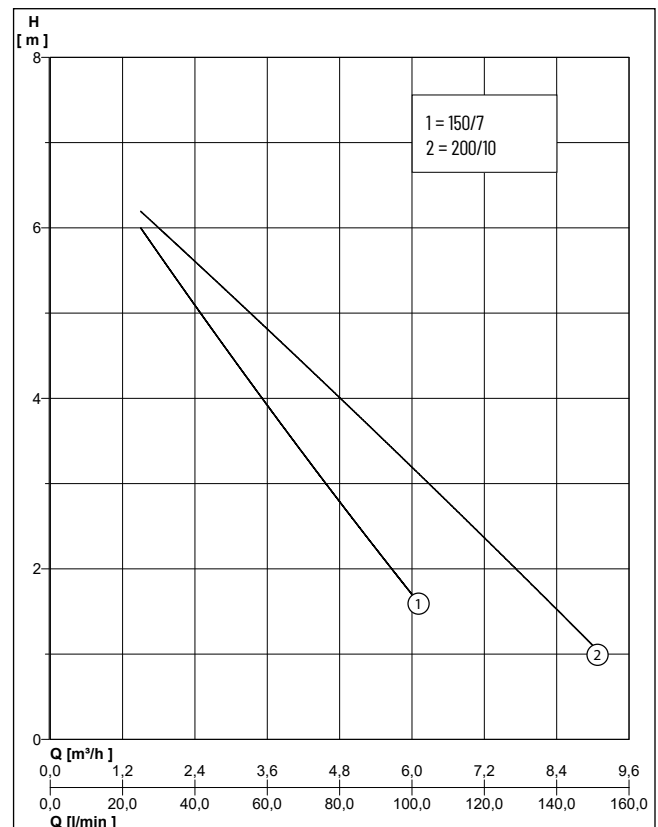

Type	Delivery head H [m]	3	4	5	6	7	8	9
DPC 150/7	Flow rate Q [m³/h]	6.2	5.6	4.9	4.2	3.4	2.5	1.5
DPC 200/10		8.0	7.3	6.6	5.6	4.7	3.6	2.3

# DPC

## CLEAN WATER DRENA-LINE

### MECHANICAL DATA

Free passage	3 mm	Pump housing	Technopolymer
Oil chamber	Yes	Submersible	Yes
Shaft	Stainless steel X 8 CrNi 18-9 (AISI 303)	Counterface	Ceramic. Lubricated in oil chamber
Impeller	Technopolymer	Temperature of the liquid max.	40 °C
Motor housing	Stainless steel X 8 CrNi 18-10 (AISI 304 )	Diving depth	7 m
		Weight	5.6 kg

### ELECTRICAL DATA

Voltage	1/N/PE~230 V	Insulation class	F
Power line	10m H05RN-F	Plug	Safety
Type of enclosure	IP 68	Rotation speed	2850 rpm

### DPC

Type	Code No.	Motor rating P1	Current	Mechanical seal
DPC 150/7	<b>N1080130</b>	0.33 kW	1.4 A	Double lip seal lubricated in oil chamber with ceramic coating bushing shaft
DPC 200/10	<b>N1080110</b>	0.65 kW	2.9 A	Double seals lubricated by oil. Primary seal: carbon graphite/ceramic mechanical seal, Secondary seal: lip seal

### DPC

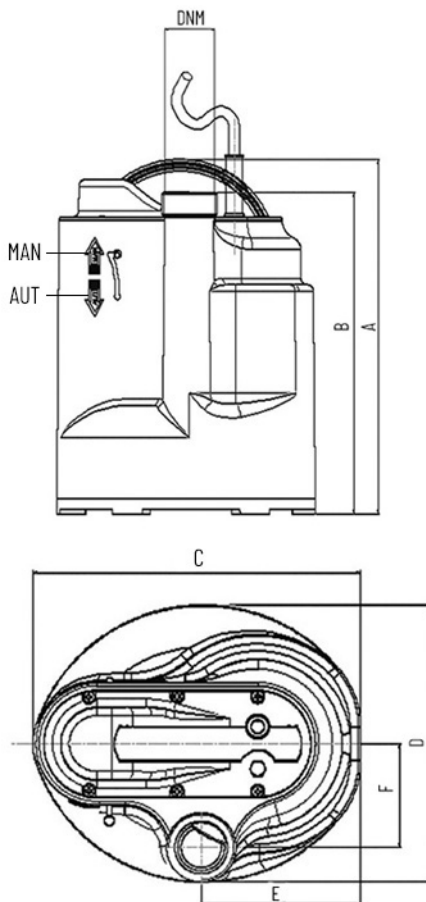

# DPC

CLEAN WATER DRENA-LINE

## DIMENSIONS [mm]

Type	A	B	C	D	F	DNM	E
DPC 150/7	273	148	200	170	63	1 1/4"	97
DPC 200/10	273	148	200	170	63	1 1/4"	97