

# FLUTBOX PRO 300

SUBMERSIBLE DRAINAGE PUMPS

- Including submersible drainage pump Multidrain UV 315-1 S
- 10 mm free passage
- Pump with cooling jacket for motor housing in submerged operation
- Quick and easy hose connection with C-coupling
- Transport box with filter function



## DESCRIPTION

The Futbox Pro 300 is a professional first aid kit for the removal of floods in basements or other flooded areas. Equipped with the powerful Multidrain 315-1 S sewage drainage pump and a 15 m pressure hose (Ø 52 mm), it can pump up to 28 m<sup>3</sup>/h. The hose is provided with a Storz-C coupling and can be extended with any regular fire hoses if required.

The pump can be used with or without the transport basket. Depending on the position of the ball float switch and without transport basket, it can dewater down to a water level of 2 cm.

The motor is permanently cooled and protected by the surrounding water and is also monitored by two thermostats. This allows the pump to operate even emerged without the risk of motor damage.

## PERFORMANCE

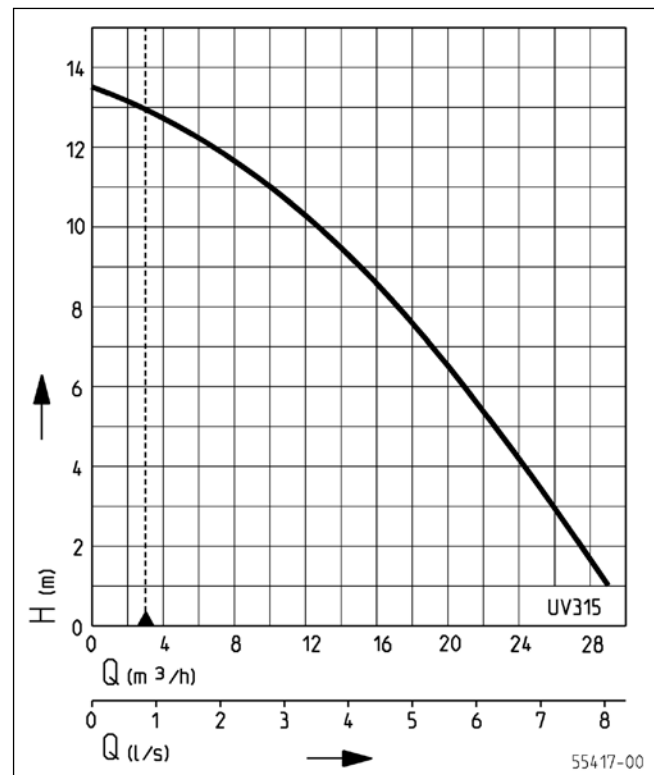

Type	Delivery head H [m]	1	2	3	5	7	9	13
Floodbox Pro 300	Flow rate Q [m <sup>3</sup> /h]	28.0	25.0	23.0	19.0	14.5	10.0	20.0

Specifications can be changed without notice. Performance subject to ISO 9906 tolerances.

The minimum flow velocity in the pressure piping must be 0.7 m/s according to EN 12056. This data is represented in the performance curve as a limit of application.

# FLUTBOX PRO 300

## SUBMERSIBLE DRAINAGE PUMPS

### SCOPE OF SUPPLY

1 submersible drainage pump Multidrain UV 315-1 S, 1 fire hose 15 m with Storz C-coupling (52 mm inner diameter), 1 tension

belt to fix the pump, e.g. during transport, 1 transport box

### MECHANICAL DATA

Pump	Vertical single-stage	Run dry protection	Yes
Free passage	10 mm	Shaft	Stainless steel
Bearing	Ball bearings, grease-lubricated	Impeller	Stainless steel
Seal on motor side	Mechanical seal	Motor housing	Stainless steel
Oil chamber	Yes	Submersible	Yes
Seal on medium side	SiC mechanical seal	Pressure outlet	C-coupling
		Weight	29 kg

### ELECTRICAL DATA

Circuit	With built-in level control	Wires	3G1,0
Voltage	1/N/PE~230 V	Type of enclosure	IP 68
Motor rating P1	1.83 kW	Insulation class	F
Motor rating P2	1.36 kW	Winding thermostat	Yes
Current	2.3 A	Motor protection	Integrated
Power line	10m H07RN8-F	Plug	Safety

### FLUTBOX PRO 300

Type	Code No.
Floodbox Pro 300	JP50586

### Dimensions Flutbox Pro 300(mm)

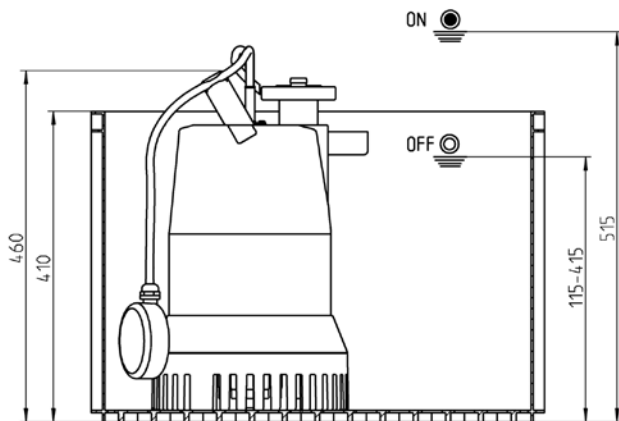

55416-00