

PKS 800

POLY-SUMP FOR SUBMERSIBLE SEWAGE PUMPS

- Mark of conformity
- Suitable for traffic up to class B 125
- Corrosion resistant components
- Patented security locking
- Inlet designed for optimised flow
- Smooth benched deposit free collection chamber
- Coupling system with guide tube
- Ball check valve with pump and pressure pipe is removable
- Rest volume from 36 litres



DESCRIPTION

The buoyancy proof sump is supplied as a complete prefabricated pump station for use in pressure drainage systems and as a sewage collection sump for use with gravity sewers. The sumps are equipped with one or two pumps. They are suitable for accessible areas (class A 15) or for traffic areas (class B 125).

Preformed transport eyelets / transport handles provide easy transport and placing into its final position.

A comprehensive range of pumps from the MultiCut sewage pump series 08/2 M to 45/2 M, with or without Ex rating together with control units which have been specially optimised for pressure drainage applications is available to ensure that the pump station meets the required discharge performance.

The buoyancy proof plastic sumps of high grade polyethylene are approved by the German Institute for Construction Engineering (DIBt) and are provided with inlet DN 150, port DN 100 for power cable and venting and a discharge branch DN 32.

The newly designed unique coupling system made of Polyphthalamide (PPA) is located above the water level. The stainless steel ball valve is provided with a safety locking device. The coupling valve can only be opened after closing the ball valve. A certified stainless steel chain and a guide tube facilitate the lifting of the pump or the coupling of the pump and coupling unit. This allows a maintenance of the ball check valve outside the sump.

Depending on the used extension it is possible to extend the sump to a total height of 2.75 metres. The required type of loading class depends on the site.

Single unit: The total volume is 640 litres. The storage volume up to the lower edge of the inlet is 145 litres and the residual volume is 36 litres.

Duplex unit: The total volume is 740 litres. The storage volume up to the lower edge of the inlet is 190 litres and the residual volume is 85 litres.

PKS 800

POLY-SUMP FOR SUBMERSIBLE SEWAGE PUMPS

SCOPE OF SUPPLY

PKS-B 800-32 (Single unit)

Plastic sump, coupling system and guide tube, stainless steel ball valve with extension and security locking. Stainless steel discharge branch DN 32 with internal thread 1/4", 2 sleeves DN 150 (KG-pipe) for the inlet (one ready for connection) and 3 ports DN 100 (KG-pipe) for cable and venting. .

PKS-B 800-D32 (Duplex unit)

Plastic sump, coupling system and guide tube, 2 stainless steel ball valves with extension and security locking. Stainless steel discharge branch DN 32 with internal thread 1/4", 1 sleeve DN 150 (KG-pipe) for the inlet, 3 ports DN 100 (KG-pipe) for cable and venting.

PSV -Sump extension Sump extension, sealing for neck of sump and 2 ports for cable and venting

DN 100 (KG-pipe).

PKS 800

Type	Code No.	Weight
PKS-B 800-32	JP09475	78 kg
PKS-B 800-D32	JP47345	80 kg

POSSIBLE PUMPS

PKS 800	MultiCut 20/2 M plus	MultiCut 36/2 M
MultiCut 08/2 ME	MultiCut 25/2 ME	MultiCut 45/2 M
MultiCut 08/2 M	MultiCut 35/2 M	

PKS 800

POLY-SUMP FOR SUBMERSIBLE SEWAGE PUMPS

APPLICATION

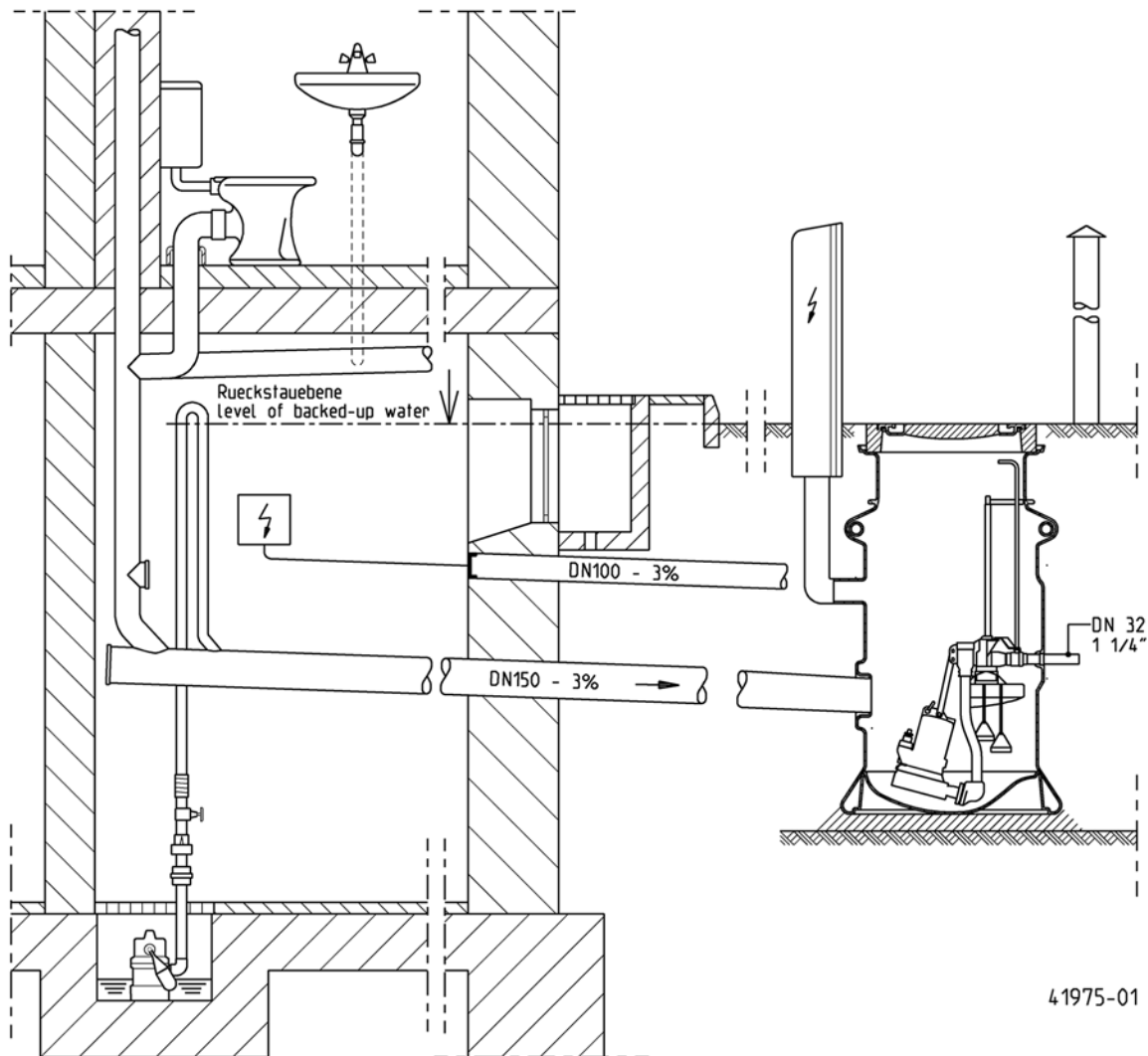

Installation characteristics

The PKS-Sump complies with all the requirements of standards DIN EN 12056/752/476 and is supplied ready for installation and connecting up. Its low weight facilitates transport and installation. It can be installed and connected in a short time without the need of expensive construction machinery.

Checking and maintenance work on the valves can be easily carried out from above - without the need to enter the sump.

Important functional features have also been taken into consideration when designing the PKS sump: a smooth benched collection chamber without any septic zones, inlets DN 150 orientated in the flow direction and a pressure tight discharge connection which is water tight resistant to any longitudinal stresses.

PKS 800

POLY-SUMP FOR SUBMERSIBLE SEWAGE PUMPS

Single unit PKS-B 800-32

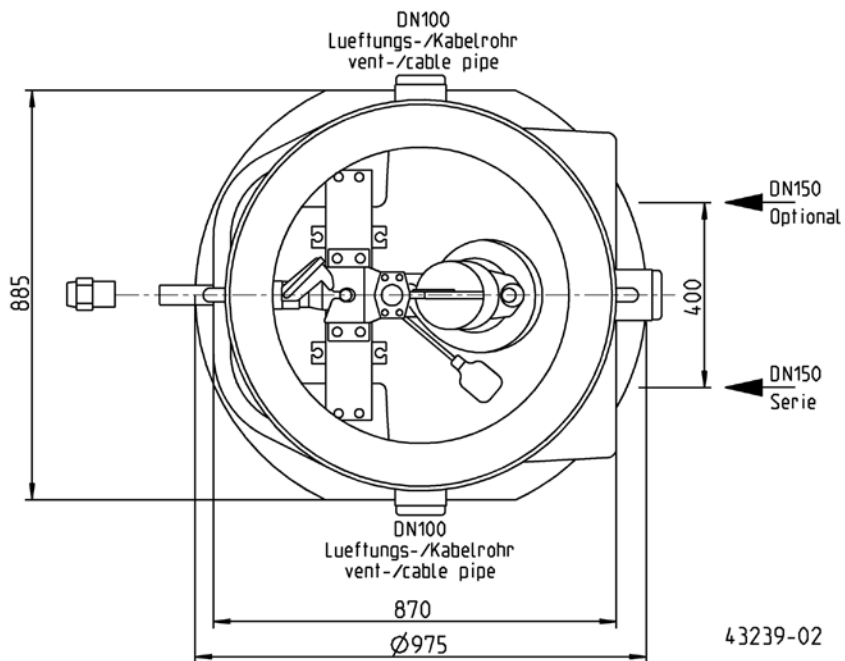
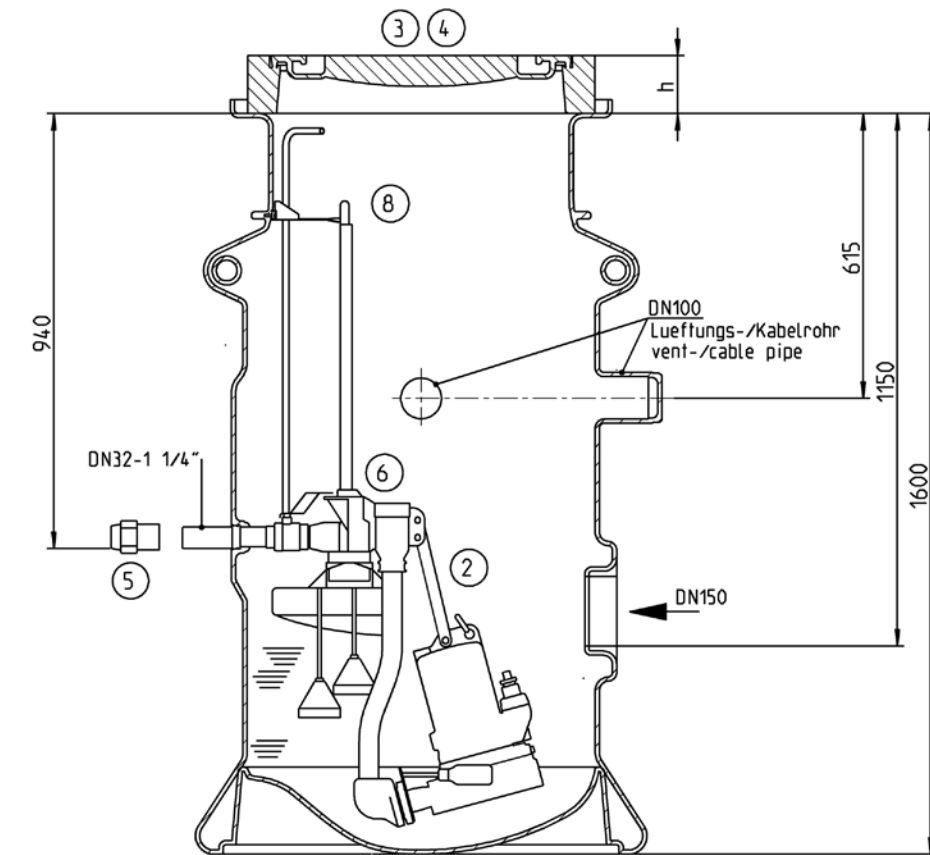

PKS 800

POLY-SUMP FOR SUBMERSIBLE SEWAGE PUMPS

Duplex unit PKS-B 800-D32

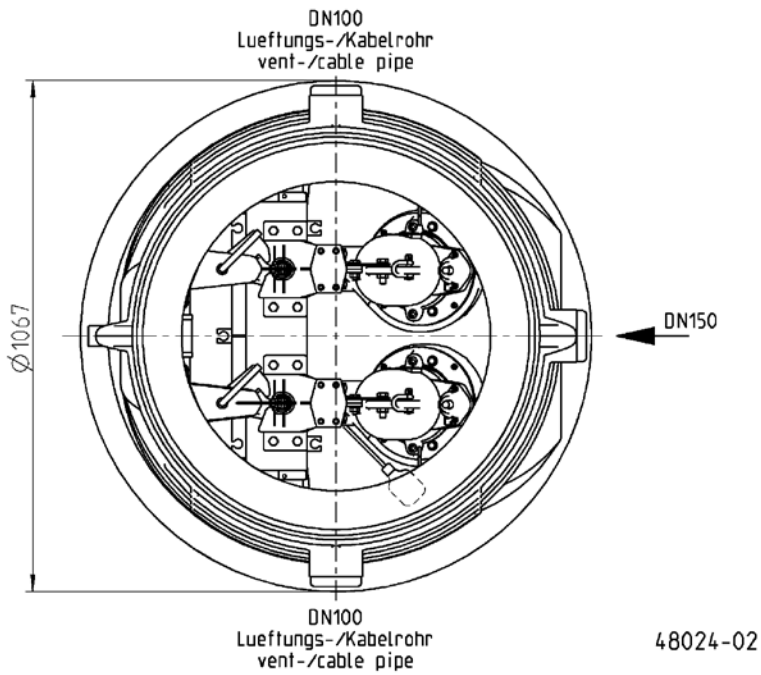
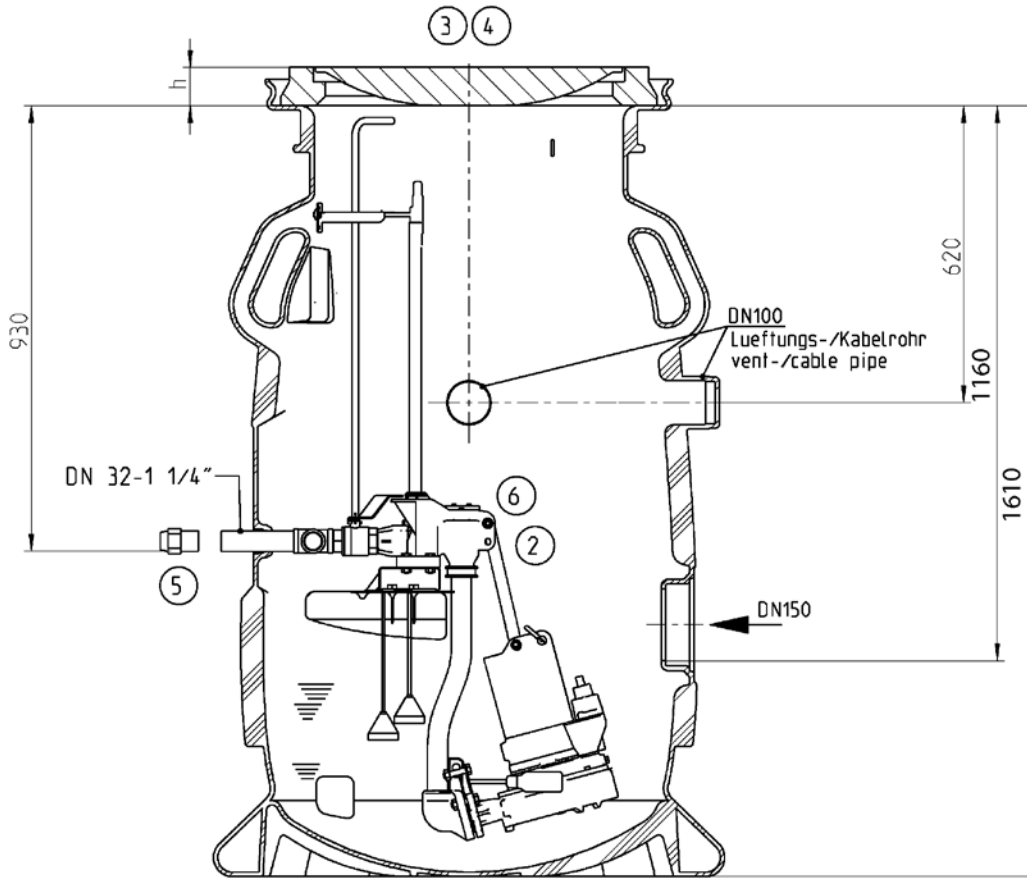

PKS 800

POLY-SUMP FOR SUBMERSIBLE SEWAGE PUMPS

Dimensions sump extensions

Single unit PKS-B 800-32

Dimensions (without cover) mm	Height	Inlet	Pressure outlet	Buoyancy proof depth
Sump	1600	1150	940	1600
Class A				
Sump + 1 x PSV-A/B 375	1975	1525	1315	1975
Sump + 1 x PSV-A 855	2455	2005	1795	2455
Sump + 1 x PSV-A 1335	2935	2485	2275	2935
Class B				
Sump + 1 x PSV-A/B 375	1975	1525	1315	1975
Sump + 2 x PSV-A/B 375	2360	1910	1700	2360
Sump + 3 x PSV-A/B 375	2740	2290	2080	2740

Volume	Sump	Extension	Switching point			
		PSV	Off	On	Alarm / peak load	UK-Inlet
PKS-B 800-32	640 l	159 l	36 l	110 l	145 l	145 l

Duplex unit PKS-B 800-D 32

Dimensions (without cover) mm	Height	Inlet	Pressure outlet	Buoyancy proof depth
Sump	1610	1160	930	1610
Class A				
Sump + 1 x PSV-A/B 375	1985	1535	1305	1985
Sump + 1 x PSV-A 855	2465	2015	1785	2465
Sump + 1 x PSV-A 1335	2945	2495	2265	2945
Class B				
Sump + 1 x PSV-A/B 375	1985	1535	1305	1985
Sump + 2 x PSV-A/B 375	2370	1920	1690	2370
Sump + 3 x PSV-A/B 375	2750	2300	2070	2750



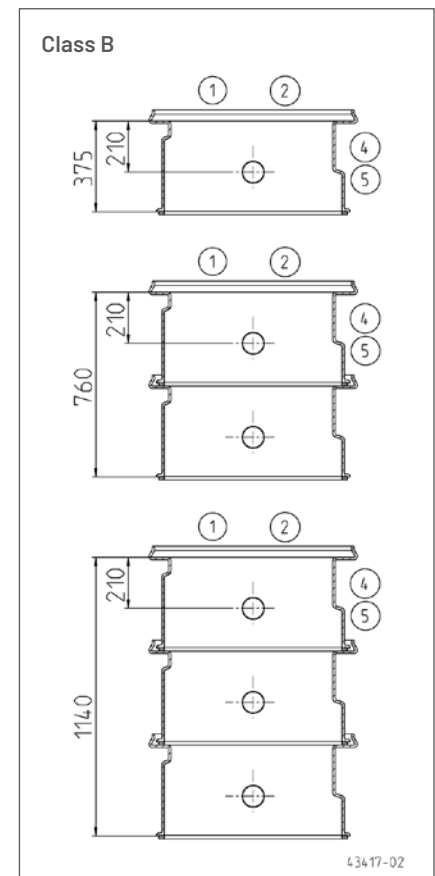
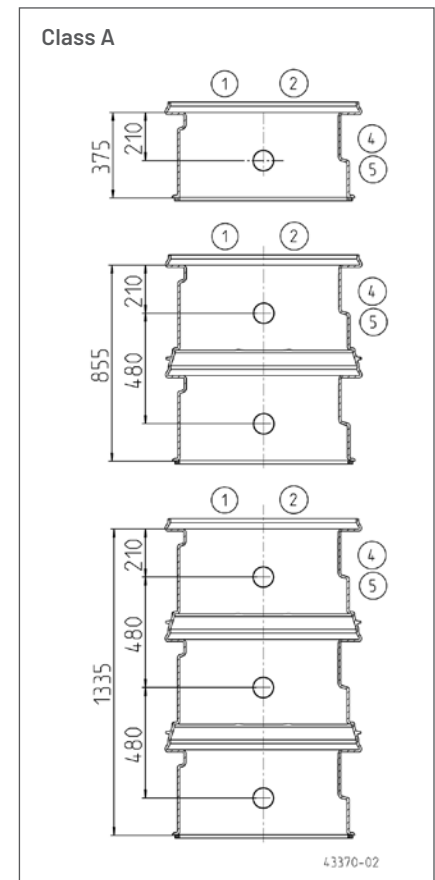





Volume	Sump	Extension	Switching point			
		PSV	Off	On	Alarm / peak load	UK-Inlet
PKS-B 800-D32	740 l	159 l	85 l	140 l	190 l	190 l

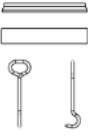

PKS 800

POLY-SUMP FOR SUBMERSIBLE SEWAGE PUMPS

SUMP ACCESSORIES

					Code No.
	① Second or changed inlet	with sealing element DN 150			JP42181
	② Discharge pipe assembly	08/2M, with 2.5 m chain	2x duplex units	8 kg	JP44857
		08/2M Ex, 20/2M - 45/2M Ex, with 2.5 m chain	2x duplex units	8 kg	JP44855
	③ Concrete cover	Cover cl. A	Ø 600, h=80, D 785	90 kg	JP46437
		Cover cl. B	Ø 610, h=125, D 750	110 kg	JP44972
	Lifting device	for cl. A			JP44969
	④ Concrete ring (max. 1)	625 x 100 mm, Ø 785		32 kg	JP44975
	⑤ Screwed joint	1 1/4" to Ø 40 mm (DN 32)			JP44796
		1 1/4" to Ø 50 mm (DN 40)			JP44797
		1 1/4" to Ø 63 mm (DN 50)			JP44798
	⑥ Breathing valve with cover				JP42179
	DRS-connection	1/2" with cover			JP42178
		+ Breathing valve with cover			JP42180
	⑦ Sump extension	PSV-A/B 375		25 kg	JP46429
		PSV-A 855		40 kg	JP46430
		PSV-A 1335		54 kg	JP46431
	Guide rail extension	PKS-B 800-32, single unit			JP46439
		PKS-B 800-D32, duplex unit			JP48064
	⑧ Operating handle T-Key	for extension, stainless steel, with 1.5 m chain			JP46438
	⑨ Ventilation pipe	DN 100 stainless steel, , 700 mm			JP44858